

150
PSI

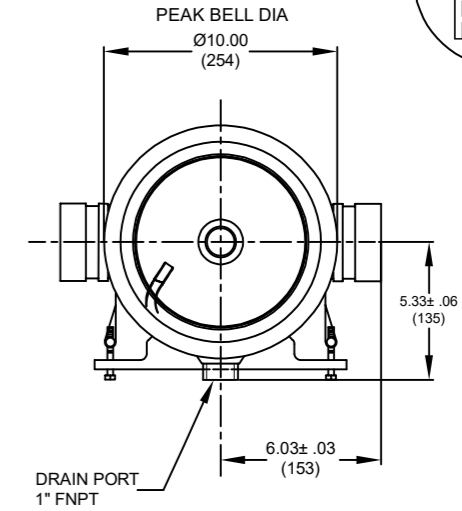

CAUTION: INCORRECT MANIFOLDING WILL CAUSE SEVERE LOCAL STRESS AROUND PORT AND MAY RESULT IN LEAKS AND PREMATURE FAILURE; TAKE EVERY PRECAUTION LISTED ON REVERSE, SEE INSTALLATION INSTRUCTIONS FOR FURTHER DETAILS

DWG REF	QTY	PART NUMBER	DESCRIPTION	MATERIAL
SHELL				
1*	1	200068	SHELL	Filament Wound Epoxy/Glass composites - Head locking grooves integrally wound in place.
2*	A/R	96327	3" Feed Port	SA-995 CD3MWCuN (UNS J933980)
3	A/R	196141	3" Port Seal	Ethylene Propylene - O - Ring
4	1	97988	1" FNPT Drain Port	Engineering Thermoplastic - Noryl
5	1	97989	1" Drain Port Seal	Sq. Seal - EPDM
HEAD COMPONENTS				
6	1	17174	1/4" FNPT Air Vent Port	Engineering Thermoplastic-PVC
7	2	196208	1/4" Air Vent Port Seal	O - Ring - EPDM
8	1	194957	Elliptical Head Assembly	-
8.1	1	194584	Elliptical Head	Engineering Thermoplastic - Noryl
8.2	1	17464	Danger Label	-
9*	1	17176	Bearing Plate Product end	SB-221 A96061-T6
10	1	117006	Sealing Plate Product end	Engineering Thermoplastic - Noryl
11	1	17187	3" Product Port	Engineering Thermoplastic - PVC
12	1	17127	3" Port Retainer Ring	SA-479 316
13	2	196223	Head Seal	O - Ring - EPDM
14	1	17128	Product Port Seal	O - Ring - EPDM
15	1	17286	Blind Plug Kit	Engineering Thermoplastic
HEAD INTERLOCK				
16*	2	47336	Quick Release Retaining Ring	SA-479 316
VESSEL SUPPORT				
17	2	52169	Saddle	Engineering Thermoplastic
18	2	45042	Strap Assy.	304 Stainless Steel-PVC Cushion.
19	4	46265	Strap screw.	5/16-18 UNC X 2.5" Long, 304 Stainless Steel.

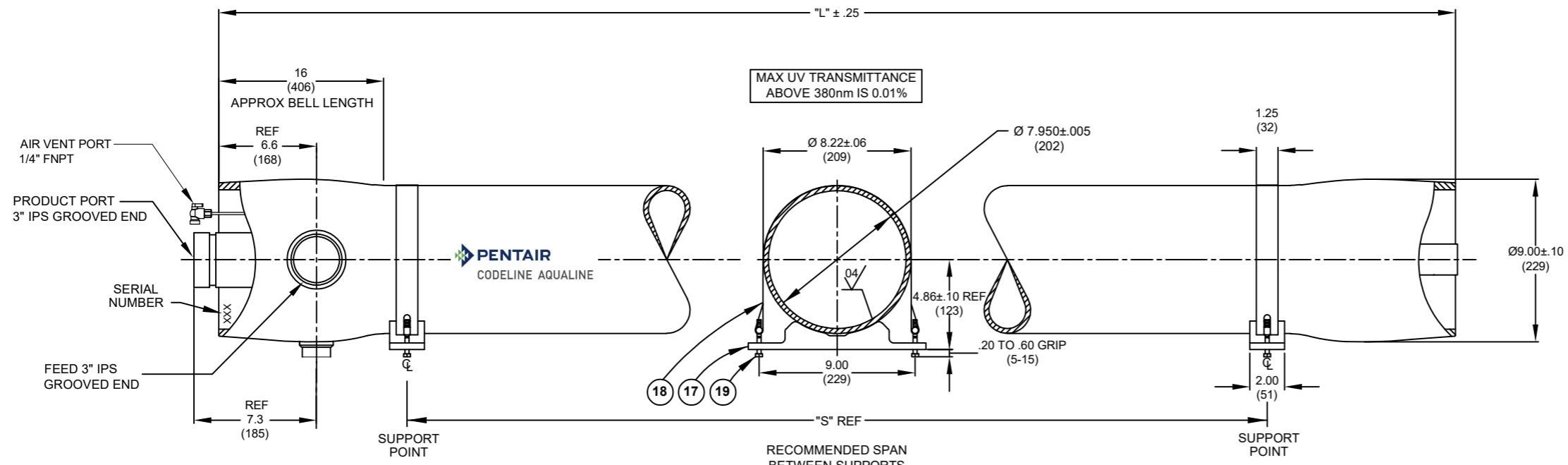
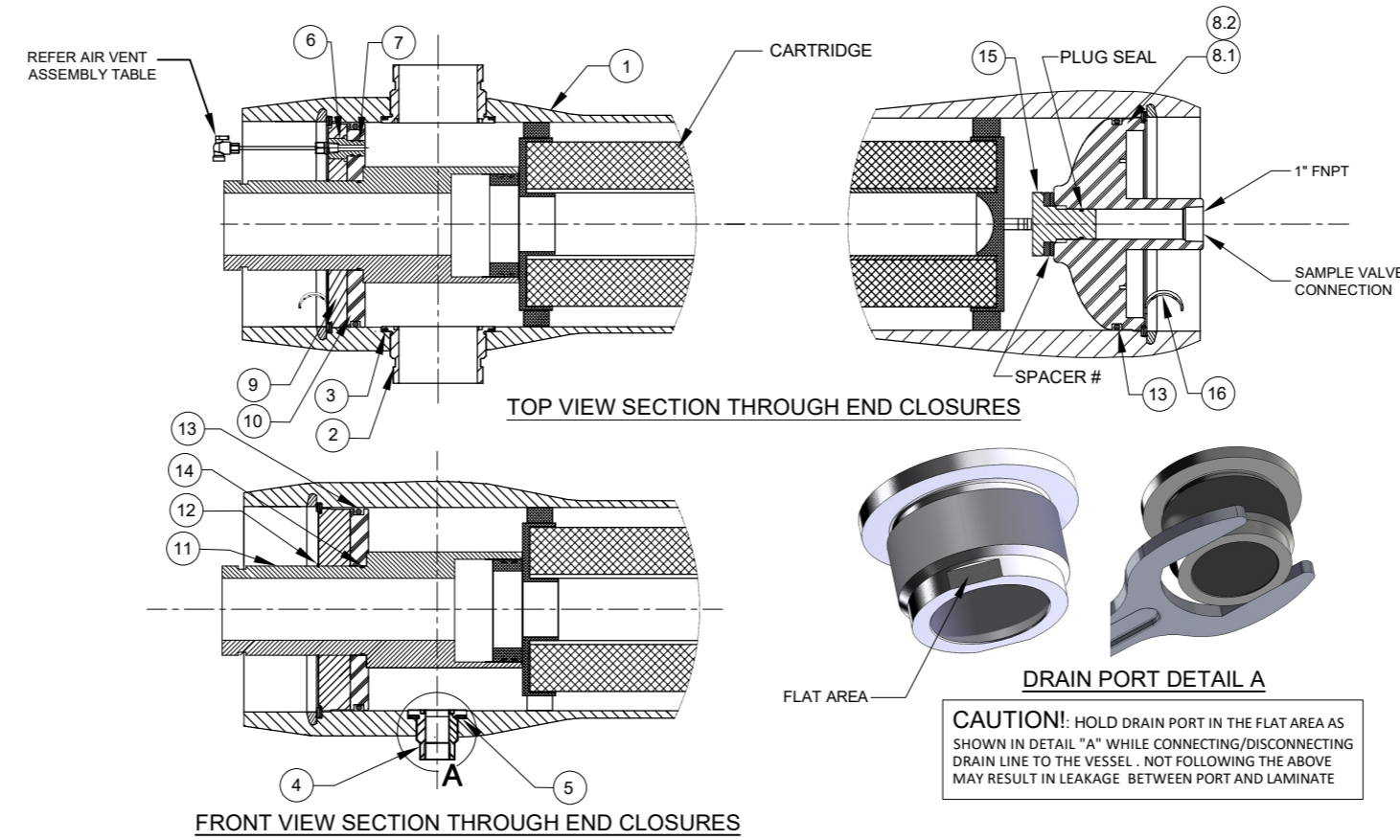

PORT SIZE CODE	
A	1" FNPT END
F	2 1/2" GROOVED END
G	3" GROOVED END

NO. OF PORTS	PORT LOCATION	VESSEL QTY.		
AIR VENT ASSEMBLY:- 17185				
ITEM	QUANTITY	PART NO.	DESCRIPTION	
1	6" Long	RRS-01027	Tubing Blue	
2	1	RRS-010013	Male Connector, Pipe 1/4" Tube 1/4"	
3	1	RRS-01047	Compression nut 1/4"	
4	1	RRS-01039	Ball Valve 1/4"	
5	1	17194	Blind Plug 1/4"	
Element	"L" IN(MM)	"S" IN(MM)	Approx Weight LB(KG)	Approx Weight With Filter LB(KG)
40	56.37 (1432)	22X1 (559)	51 (23)	64 (30)
60	76.37 (1940)	42X1 (1067)	55 (25)	68 (31)

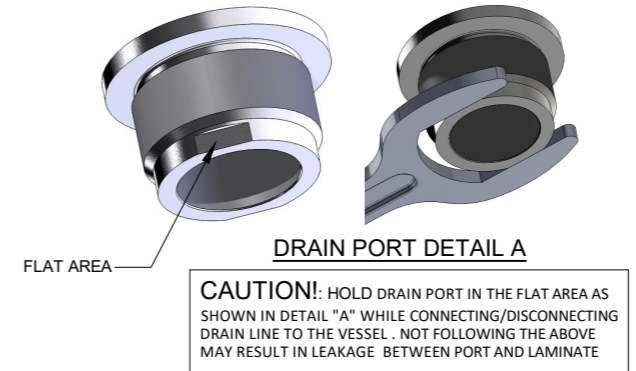

GENERAL NOTES:
 1. DIMENSION IN INCHES (MM APPROX.).
 2. SHELL EXTERIOR COATED WITH WHITE RAL 9003, HIGH GLOSS POLYURETHANE PAINT.
 3. NOT TO BE USED FOR CONSTRUCTION UNLESS CERTIFIED BY PENTAIR.
 ** WEIGHT MENTIONED IS WITHOUT CARTRIDGE AND WATER.
 • CARTRIDGE SHOWN FOR REPRESENTATION ONLY & TO BE PURCHASED SEPARATELY.
 # SPACER TO BE USED IF REQUIRED IN ASSEMBLY.
 * ASME PARTS.

THIS DOCUMENT AND THE INFORMATION CONTAINED HEREIN, ARE THE CONFIDENTIAL AND PROPRIETARY INFORMATION OF PENTAIR WATER INDIA PVT. LTD. PENTAIR WATER INDIA PVT. LTD. IS THE SOLE OWNER OF THE INFORMATION AND PROCESSES DEFINED HEREIN. THIS DOCUMENT, AND THE INFORMATION CONTAINED, MAY NOT BE DISCLOSED, REPRODUCED, DUPLICATED, USED, SOLD, PUBLISHED, COMMUNICATED OR OTHERWISE DISTRIBUTED, IN WHOLE OR IN PART, FOR ANY PURPOSE WITHOUT THE EXPRESS WRITTEN CONSENT OF PENTAIR WATER INDIA PVT. LTD. THIS DOCUMENT AND ANY COPIES, IN ALL APPLICABLE FORMATS, SHALL BE RETURNED TO PENTAIR WATER INDIA PVT. LTD. UPON REQUEST.

ALL INDICATED PENTAIR TRADEMARKS AND LOGOS ARE PROPERTY OF PENTAIR. THIRD PARTY REGISTERED AND UNREGISTERED TRADEMARKS AND LOGOS ARE PROPERTY OF THEIR RESPECTIVE OWNERS. BECAUSE WE ARE CONTINUOUSLY IMPROVING OUR PRODUCTS AND SERVICES, PENTAIR RESERVES THE RIGHT TO CHANGE SPECIFICATIONS WITHOUT PRIOR NOTICE. PENTAIR IS AN EQUAL OPPORTUNITY EMPLOYER.

©2021 Pentair. All Rights Reserved.

VERNA, GOA INDIA

DRAWN BY: SV	DRAWING DESCRIPTION: MODEL: 80AQ15 SINGLE CARTRIDGE HOUSING	DRAWING NO.: 200222	REV.: M
DATE: 14MAR18	CUSTOMER NAME: -	VESSEL MODEL: 80AQ15 NC	
CHECKED BY: KPS	DATE: 14MAR18	PROJECT NAME: -	TOTAL QTY: -
APPROVED BY: MKS	DATE: 14MAR18	CUSTOMER P.O.#: -	SIZE: A3
ECN NO.: 6799	SCALE: NONE	REV. DATE: 28MAY24	PAGE NO.: 01 OF 02

RATING:

DESIGN PRESSURE/MAWP.....150 PSIG
(1.03MPa)
MAX. ALLOWABLE TEMP.....113°F
(45°C)
MIN. ALLOWABLE TEMP.....20°F
(-7°C)
FACTORY TEST PRESSURE..... 165 PSIG
(1.14 MPa)
QUALIFICATION PRESSURE..... 900 PSI
(6.21 MPa)

INTENDED USE:

The AquaLine 80AQ15 Non Coded Fiberglass Pressure Vessel is designed for continuous, long term use as housing for AquaLine range of micro filtration elements.

The Shell of AquaLine 80AQ15 Non Coded vessel is designed in accordance with the engineering standards of the Boiler and Pressure Vessel Code of the American Society of Mechanical Engineers (ASME) as per Section X Edition 2023 and all metallic parts are designed as per ASME Section VIII Division I Edition 2023.

The AquaLine 80AQ15 Non Coded vessel must be installed, operated and maintained in accordance with the listed precautions and good industrial practice to assure safe operation over a long service life.

The high performance Filament wound FRP shell must be allowed to expand under pressure; undue restraint at support points or piping connections can cause leaks to develop in the shell. This side-ported vessel requires special precautions in mounting and connection to piping so that the vessel will not be subjected to excessive stress due to bending moments acting at the side openings in the fiberglass shell. The end closure, incorporating close fitting, interlocking metal components, must be kept dry and free of corrosion; deterioration can lead to catastrophic mechanical failure of the head.

Pentair will assist the purchaser in determining the suitability of this standard vessel for their specific operating conditions. The final determination however, including evaluation of the standard material of construction for compatibility with the specific corrosive environment, shall be the responsibility of the purchaser. Alternate materials with enhanced corrosion resistance are available on special order.

Specifications are subject to change without notice.

PRECAUTIONS:

DO...read, understand and follow all instructions; failure to take every precaution will void warranty and may result in vessel failure

DO...mount the shell on horizontal/vertical members at span "S" using compliant vessel supports furnished; for mounting vessels vertically provide proper bottom support; tighten hold down straps just snug.

DO...align and center side ports with the manifold header. Correct, causes of misalignment in a row of vessels connected to the same header

DO...use flexible type IPS grooved-end pipe couplings, or equal, at side ports; allow full, 0.125 inch gap between port and piping, and position piping to maximize flexibility of connection.

DO...provide flexibility in, and support for piping manifolds so that vessel can grow in length under pressure without undue restraint; provide additional flexible joints in large pipes leading to manifold header.

DO... Lubricate seals sparingly, using nonpetroleum Based lubricants, i.e. Parker Super O-lube®, Glycerin or suitable silicone based lubricants.

DO...provide overpressure protection for vessel set at not more than 105% of design pressure

DO...inspect end closures regularly; replace components that have deteriorated and correct causes of corrosion

DO NOT...work on any component until first verifying that pressure is relieved from vessel

DO NOT...make rigid piping connections to ports or clamp vessel in any way that resists growth of fiberglass shell under pressure;

DO NOT...pressurize vessel until double-checking to verify that the Spiral Ring is in place and fully seated.

DO NOT...operate vessel at pressure and temperature in excess of its rating.

DO NOT...tolerate leaks or allow end closures to be routinely wetted in any way

DO NOT...operate outside the pH range of 3-11.

DO NOT...operate outside the pH range 2-12 for cleaning.

DO NOT...exceed 43.5 hours in a year for cleaning with above mentioned pH range.

For complete information on proper use of the vessel
Please refer to the 80AQ15 User Guide No 98760.

ORDERING:

Using the chart below, please check the features you require.

VESSEL LENGTH CODE

MODEL: AquaLine 80AQ15 Non Coded -40 -60

CERTIFICATION REQUIRED

- Hydro testing at 1.1 times the design pressure.
- CE Marked – MODULE-D1, CATEGORY-2.

FEED PORT CONFIGURATION

Please fill out quantity for each configuration

- 1 A 4 G (Standard)
- 1 A 2 G (Optional)
- 1 A 2 G 4 G (Optional)
- *1 A 4 F (Optional)
- *1 A 2 F (Optional)
- *1 A 2 F 4 F (Optional)

DRAIN PORT

- 1" FNPT CONNECTION - Noryl (Standard)
- 1" FNPT CONNECTION – CD3MWCuN (P/N 17180) (Optional)
Note: P/N 45340 – 1" Drain Port Seal has to be used with port P/N 17180

FEED PORT (OPTIONAL)

- 3" IPS GROOVED CONNECTION – CD3MWCuN (P/N 98804)
Note: 1. For vessel center to feed port height (6.38 ± .03) as per 80CF15 Non-Coded.
- 2.5" IPS GROOVED CONNECTION – NORYL (P/N 98650)
Note: 1. For vessel center to feed port height (6.03 ± .03)
2. P/N 196255, 2.5" Feed Port Seal has to be used with port P/N 98650.

SAMPLE VALVE KIT – 17467 (OPTIONAL)

- Yes

ITEM	QUANTITY	PART NO.	DESCRIPTION
1	1	96524	BALL VALVE 1/2"
2	1	96526	ADP 1/2" MNPT X 1" MNPT
3	1	17468	SAMPLE PLUG KIT

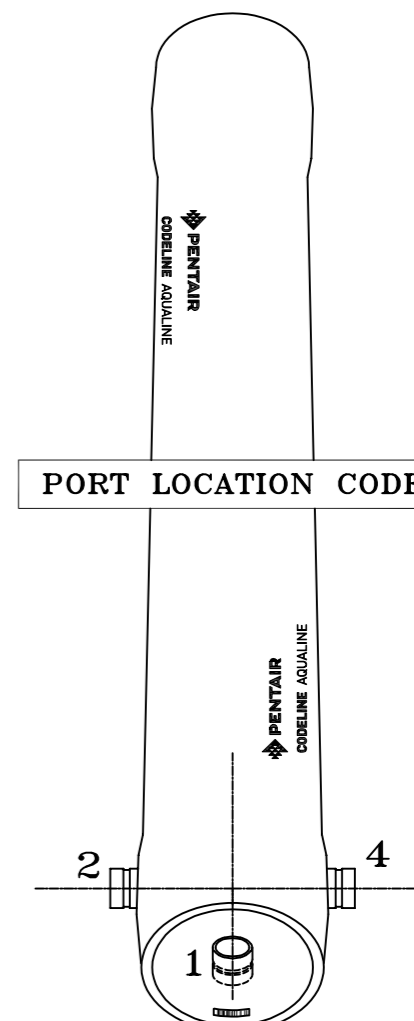

CODELINE AQUALINE BODY LABELS ARE PLACED AT 90° ON SERIAL NUMBER END AND AT 270° ON THE OPPOSITE SIDE END

GENERAL NOTES:

* ONLY FOR 80AQ15-40 NC MODEL.

THIS DOCUMENT AND THE INFORMATION CONTAINED HEREIN, ARE THE CONFIDENTIAL AND PROPRIETARY INFORMATION OF PENTAIR WATER INDIA PVT. LTD. PENTAIR WATER INDIA PVT. LTD. IS THE SOLE OWNER OF THE INFORMATION AND PROCESSES DEFINED HEREIN. THIS DOCUMENT, AND THE INFORMATION CONTAINED, MAY NOT BE DISCLOSED, REPRODUCED, DUPLICATED, USED, SOLD, PUBLISHED, COMMUNICATED OR OTHERWISE DISTRIBUTED, IN WHOLE OR IN PART, FOR ANY PURPOSE WITHOUT THE EXPRESS WRITTEN CONSENT OF PENTAIR WATER INDIA PVT. LTD. THIS DOCUMENT AND ANY COPIES, IN ALL APPLICABLE FORMATS, SHALL BE RETURNED TO PENTAIR WATER INDIA PVT. LTD. UPON REQUEST.

ALL INDICATED PENTAIR TRADEMARKS AND LOGOS ARE PROPERTY OF PENTAIR. THIRD PARTY REGISTERED AND UNREGISTERED TRADEMARKS AND LOGOS ARE PROPERTY OF THEIR RESPECTIVE OWNERS. BECAUSE WE ARE CONTINUOUSLY IMPROVING OUR PRODUCTS AND SERVICES, PENTAIR RESERVES THE RIGHT TO CHANGE SPECIFICATIONS WITHOUT PRIOR NOTICE. PENTAIR IS AN EQUAL OPPORTUNITY EMPLOYER.

©2021 Pentair. All Rights Reserved.

PENTAIR
CODELINE AQUALINE
VERNA, GOA
INDIA

DRAWN BY: SV	DRAWING DESCRIPTION: MODEL: 80AQ15 SINGLE CARTRIDGE HOUSING	DRAWING NO.: 200222	REV.: M
DATE: 14MAR18	CUSTOMER NAME: -	VESSEL MODEL: 80AQ15 NC	
CHECKED BY: KPS	PROJECT NAME: -	TOTAL QTY: -	
DATE: 14MAR18	CUSTOMER P.O.#: -	SIZE: A3	SCALE: NONE
APPROVED BY: MKS	REV. DATE: 28MAY24	PAGE NO.: 02 OF 02	
DATE: 14MAR18			